



# INSTALLATION MANUAL

# SUBMERSIBLE WELL PUMPS

**CONSUMER HOT-LINE:**  
**1-800-942-3343**  
**MONDAY - FRIDAY • 7 AM to 5 PM**  
EASTERN STANDARD TIME

TWO WIRE SUBMERSIBLES W/GROUND

**MODELS R200A, R201A, R202A,  
R203A, R214A, R2254A  
& R2354A**  
1/2 to 1-1/2 HP

THREE WIRE SUBMERSIBLES W/GROUND

**MODELS R300A, R301A, R302A,  
R314A, R3183A, R3184A,  
R3065A, R3067A, R3207A,  
R31015A, R30610A, R3254A,  
R3354A, R32551A & R33551A**  
1/2 to 2 HP



**WARRANTY: PRODUCT DEFECTS COVERED  
12 MONTHS FROM DATE OF PURCHASE OR  
18 MONTHS FROM DATE OF MANUFACTURE.  
RECEIPT AND PRODUCT DATE CODE  
REQUIRED FOR WARRANTY CLAIM.**

**WATER ACE PUMP COMPANY • ASHLAND, OHIO 44805-1969**

23833A019

## WARNING! IMPORTANT SAFETY INSTRUCTIONS! READ CAREFULLY BEFORE INSTALLATION



**FAILURE TO FOLLOW THESE INSTRUCTIONS AND COMPLY WITH ALL CODES MAY CAUSE SERIOUS BODILY INJURY AND/OR PROPERTY DAMAGE.**

⚠ **1)** Before installing or servicing your pump, **BE CERTAIN THE PUMP POWER SOURCE IS TURNED OFF AND DISCONNECTED.**

⚠ **2)** All installation and electrical wiring must adhere to state and local codes. Check with appropriate community agencies, or contact your local electrical and pump professionals for help.

⚠ **3) CALL AN ELECTRICIAN WHEN IN DOUBT.**

Pump must be connected to a separate electrical circuit directly from the entrance box. There must be an appropriately sized fuse or circuit breaker in this line. Tying into existing circuits may cause circuit overloading, blown fuses, tripped circuit breakers, or a burned up motor.

⚠ **4)** Do not connect pump to a power supply until the pump is grounded. For maximum safety, a ground fault interrupter should be used. **CAUTION: FAILURE TO GROUND THIS UNIT PROPERLY MAY RESULT IN SEVERE ELECTRICAL SHOCK.**

⚠ **5) WARNING:** Reduced risk of electric shock during operation of this pump requires the provision of acceptable grounding:

**a)** If the means of connection to the supply-connection box is other than grounded metal conduit, ground the pump back to the service by connecting a copper conductor, at least the size of the circuit conductors supplying the pump, to the grounding screw provided within the wiring compartment.

**b)** This pump is provided with a means for grounding. To reduce the risk of electric shock from contact with adjacent metal parts, bond supply box to the pump-motor-grounding means and to all metal parts accessible at the well head, including metal discharge pipes, metal well casing, and the like, by means of

**(1)** an equipment-grounding conductor at least the size of the well cable conductors, or the equivalent, that runs down the well with the well cable and,

**(2)** a clamp, a weld, or both if necessary, secured to the equipment-grounding lead, the equipment-grounding terminal, or the grounding conductor on the pump housing. The equipment-grounding lead, if one is provided, is the conductor that has an outer surface of insulation that is green with or without one or more yellow stripes.

⚠ **6)** The voltage and phase of the power supply must match the voltage and phase of the pump.

⚠ **7)** Do not use an extension cord; splices must be made with an approved splice kit and should be checked for integrity before submerging in water, above ground joints must be made in an approved junction box.

⚠ **8)** Do not work on this pump or switch while the power is on.

⚠ **9)** Never operate a pump with a frayed or brittle power cord, and always protect it from sharp objects, hot surfaces, oil and chemicals. Avoid kinking the cord.

⚠ **10)** Never service a motor or power cord with wet hands or while standing in or near water or damp ground.

⚠ **11)** The three phase units must be wired by a qualified electrician, using an approved starter box and switching device.

⚠ **12)** Do not use this pump in or near a swimming pool, pond, lake or river.

⚠ **13)** Single phase motors are either two wire units (two black power wires and a green ground), or three wire units (three power leads red, black, and yellow and a green ground). The three wire units require a control box. Make sure the control box matches the motor in voltage, horsepower, and phase.

⚠ **14)** Single phase motors are equipped with automatic resetting thermal protectors. The motor may restart unexpectedly causing the leads to energize or pump to turn. Three phase motors should be protected by proper thermal and amperage protection. (Check local codes.)

⚠ **15)** Check for nicks in the wire and pump insulation by using an ohm meter and checking resistance to ground before installing the pump and after installing the pump. If in doubt on the proper procedure check with a qualified electrician.

⚠ **16)** Do not pump gasoline, chemicals, corrosives, or flammable liquids; they could ignite, explode, or damage the pump, causing injury and voiding the warranty.

⚠ **17)** Do not run this pump with the discharge completely closed. This will create superheated water, which could damage the seal, and shorten the life of the motor. This superheated water could also cause severe burns. Always use a pressure relief valve, set below the rating of the tank or system.

**CAUTION!**

⚠ **18)** Pump is capable of building pressures in excess of 100 PSI. Always use a pressure relief valve.

⚠ **19)** The well, cistern, or pit must be sealed to prevent a child, animal or foreign object from falling in.

⚠ **20)** While the well seal or cap is removed for repairs, cover the well to prevent foreign matter from entering, contaminating the well, and possibly damaging the pump.

⚠ **21)** Test well water for potability; chlorinating the well or purifying, is recommended every time the well is opened. Check with local Health Departments for testing and sanitizing procedures.

**CAUTION!**

⚠ **22)** The following may cause severe damage to the pump and void warranty. It could also result in personal injury:

- Running the pump dry.
- Failure to protect the pump from below freezing temperatures.
- Running the pump with the discharge completely closed.
- Pumping chemicals or corrosive liquids.

⚠ **23)** Never work on the pump or system without relieving the internal pressure.

⚠ **24)** Do not pump water above 120° Fahrenheit.

⚠ **25)** Never exceed the pressure rating of any system component.



---

## FINDING THE DEPTH OF YOUR WELL

Tie a small but heavy weight to the end of a piece of string (be sure there is enough string; some wells are very deep). Lower weight into well until it reaches bottom. Take up slack and mark string at ground level. Pull weight out of well and measure from bottom of weight to ground level mark. This is the depth of your well. Subtract ten feet from this depth. This number should not exceed the pumping depth of your pump. If it does, it will greatly hinder or prevent the proper operation of the pump (See tables on page 8). Subtract twelve feet from the depth of your well. This is the approximate length of polytubing or piping needed to install pump.

## PIPING

For wells 200 feet or less in depth, 160# tested polytubing may be used. For 200 to 300 feet, PVC pipe may be used. For greater depths, galvanized steel pipe is recommended. (On **deep** settings, we recommend that a check valve be installed in the pipe 200-ft. above the pump and every 200-ft. thereafter to prevent water shock from traveling back to pump.)

---

## SUBMERSIBLE WELL PUMP INSTALLATION

Polytubing is shown in the illustrations, but for greater depths, PVC pipe or galvanized steel pipe may be used (see "PIPING" above). All materials with part numbers are quality Water Ace parts.

### General Materials for Pitless Adapter Installation

- 5" inside diameter well casing or larger
- One can PVC cement (read instructions carefully).
- One can thread compound (read instructions carefully).
- One roll of plastic tape.
- Two male 1-1/4" barbed adapters.
- Enough 1-1/4" piping to reach from well bottom to well opening.
- Four hose clamps large enough to clamp 1-1/4" pipe.
- One torque arrestor RTA-10-12 (includes clamps).
- One pitless adapter RCPA-1.
- One well cap.
- One tank cross RTC290-1
- One relief valve RRV-5
- One 3/4" boiler drain
- One pressure gauge RG-2
- Pressure switch RPS with 1/4" x 3" brass nipple.

- One 1-1/4" to 1" female to male PVC reducer.
- Two male 1" PVC adapters.
- Enough rigid 1" PVC pipe to reach from well opening to pressure tank to service line.
- One Water Ace control box  
**(for 3-wire submersibles only).**
- Enough strong rope to reach from pump to well cap.

### In addition to General Materials, for Well Seals

- 4" well casing or larger
- Galvanized steel 8" x 1-1/4" nipple in place of pitless adapter.
- 1-1/4" to 1" male PVC reducer in place of 1-1/4" to 1" female to male PVC reducer.
- Water Ace well seal in place of well cap.
- Galvanized steel 1-1/4" female coupling.
- Galvanized steel 1-1/4" elbow.

### Tools Needed for all submersible installations

Pipe wrench, crescent wrench, slot screwdriver, 24-tooth hacksaw, knife or round file, wire crimpers

**REMINDER: ALL JOINTS AND CONNECTIONS MUST BE AIRTIGHT. A SINGLE PIN-HOLE LEAK WILL PREVENT THE PROPER OPERATION OF THE PUMP. USE THREAD COMPOUND ON ALL THREADED CONNECTIONS UNLESS SPECIFIED OTHERWISE.**

Do not use thread compound or teflon tape on pump discharge.

## PITLESS ADAPTER INSTALLATION

**STEP 1** The pump assembly must be assembled on the ground before lowering into the well. Lay out all necessary materials near the well.

**STEP 2** Thread 1-1/4" male barbed adapter into top of pump. **Do not use thread compound or teflon tape on pump discharge.**

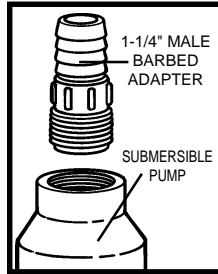

**STEP 3** Subtract twelve feet from the depth of well (See page 3 "Finding the Depth of Your Well"). This is the total length of polytubing needed to clamp onto the 1-1/4" male barbed adapter. Slide two hose clamps and the two hose clamps packed with torque arrestor over end of polytubing. Clamp polytubing onto barbed end of 1-1/4" male adapter with two hose clamps.

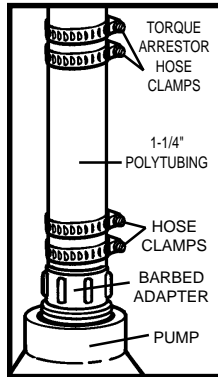

**STEP 4** Remove Pitless Adapter RCPA-1 from box. Remove black washers and lock nut with fitting from adapter. The adapter is composed of two main parts: the pipe junction, and the slot. Slide pipe junction out of slot, and thread 1-1/4" to 1" female to male PVC reducer into bottom of it.

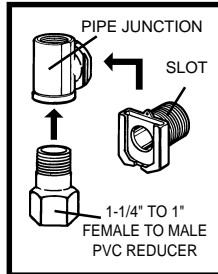

**STEP 5** Thread 1-1/4" male barbed adapter into 1-1/4" to 1" female to male PVC reducer.

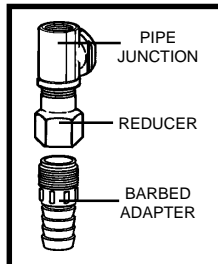

**STEP 6** With two hose clamps, clamp the other end of the polytubing onto the male barbed adapter.

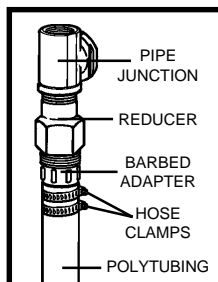

**STEP 7** Remove well cap from top of well casing. There should be a hole on the side of the casing for the pitless adapter slot. If not, cut one. Slide a rubber washer onto slot. Reach down into casing and slide slot through hole in the side of the casing. Place other washer, fitting, and lock nut on slot threads protruding from casing. Tighten securely.

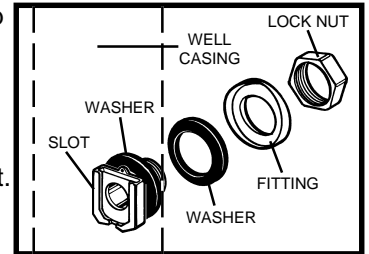

**STEP 8** The slot has interior threads as well. Thread a 1" male PVC adapter into the slot.

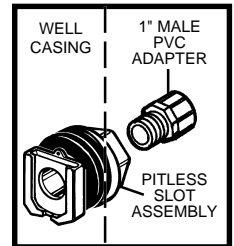

**STEP 9** Slide one black shrink tube over each wire coming out of the pump.

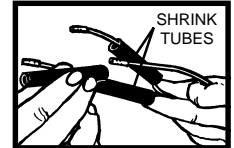

**STEP 10** Determine the length of wire needed to reach from the pump to the power supply. Crimp this length of wire onto each of the wires coming out of the pump.

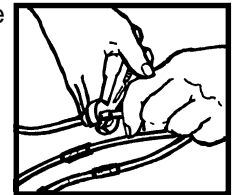

**STEP 11** Slide one shrink tube over crimped joint. Apply heat with torch or butane lighter. Heat one tube at a time. Do not let tubes touch each other while heating. When liquid oozes from end of tube, seal is complete. See "Cable Splice Check" on page 6 to check for leaks.

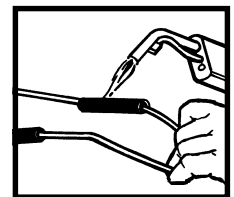

**STEP 12** Determine length of rope needed to reach from well cap to loop at top of pump. Tie one end of rope to pump loop, and the other to well cap. This is your only security against losing the pump down the well.

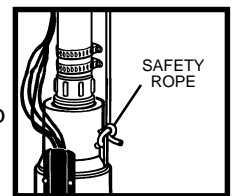

**STEP 13** Tape wires securely to polytubing every five feet with plastic tape. Tape safety rope every ten feet.

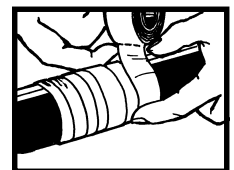

**STEP 14** Firmly clamp the torque arrestor to polytubing about four inches above pump.

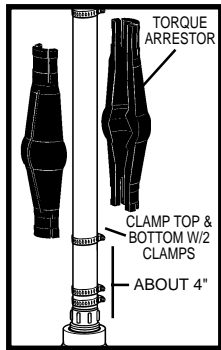

**STEP 15** With someone's help, carefully lower pump assembly into well. Slide pitless pipe junction into pitless slot.

Firmly grasp assembly and safety rope tied to well cap to prevent assembly from falling into the well. Once pipe junction is in slot, thread wires through well cap. Leave slack in wire in top of casing for polytube stretch. Thread riser pipe into top of pipe junction. Replace well cap.

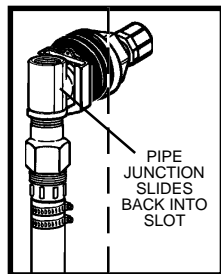

**STEP 16** Thread 10" x 1" nipple into pressure tank. Thread tank cross #RTC290-1 into nipple so that the two 1/4" holes in tank cross face upward. Thread street tee into front of tank cross. Thread pressure relief valve #RRV-75 into top of street tee and thread 3/4" boiler drain into front of street tee.

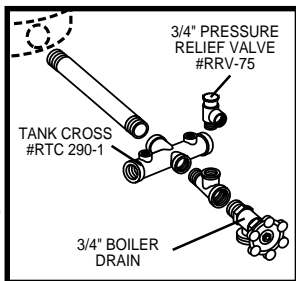

**STEP 17** Thread 1" male PVC adapter into the inlet side of tank cross.

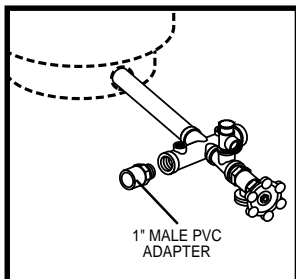

**STEP 18** Thread one end of 1/4" x 3" brass nipple into bottom of pressure switch #RPS. Thread other end into left 1/4" hole of tank cross. Thread pressure gauge #RG-2 into right 1/4" hole of tank cross. Cut and cement as many sections and couplings of PVC pipe needed to connect the 1" male PVC adapter on the gate valve to 1" male PVC adapter on the pitless slot assembly. Complete installation should look like the drawing on the following page.

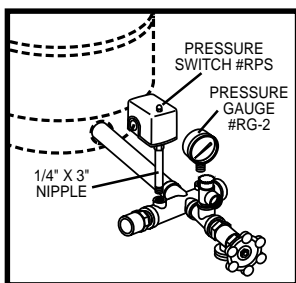

## WELL SEAL INSTALLATION

**STEP 1** FOLLOW STEPS 1-3 IN THE PITLESS ADAPTER INSTALLATION INSTRUCTIONS.

**STEP 2** Thread 1-1/4" galvanized steel female adapter onto 8" galvanized steel nipple.

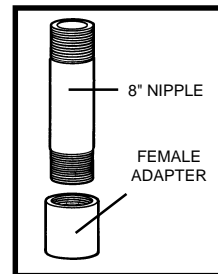

**STEP 3** Thread 1-1/4" male barbed adapter into galvanized steel female adapter.

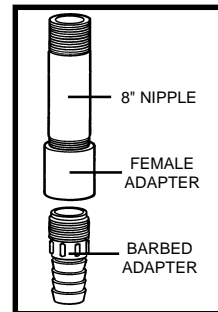

**STEP 4** Clamp the other end of polytubing onto barbed adapter with two clamps. FOLLOW STEPS 9-14 IN THE PITLESS ADAPTER INSTALLATION INSTRUCTIONS.

**STEP 5** Slide well seal over 8" galvanized steel nipple. Slide wires through one of the smaller holes in the well seal, leaving slack for polytube stretch. Slide safety rope through other hole in well seal and tie rope around discharge pipe.

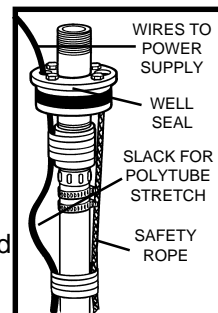

**STEP 6** Thread 1-1/4" galvanized steel elbow onto 8" galvanized steel nipple. Thread 1-1/4" to 1" male PVC reducer into elbow.

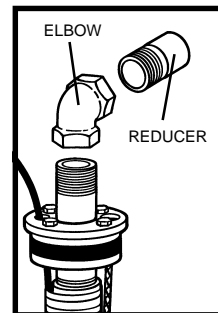

**STEP 7** With someone's help, carefully slide pump assembly down well. Turn well seal nuts clockwise until well seal firmly clamps 8" galvanized steel nipple. FOLLOW STEPS 16-18 IN PITLESS ADAPTER INSTALLATION INSTRUCTIONS. Complete assembly should look like the drawing on the following page.

## LOWERING THE PUMP

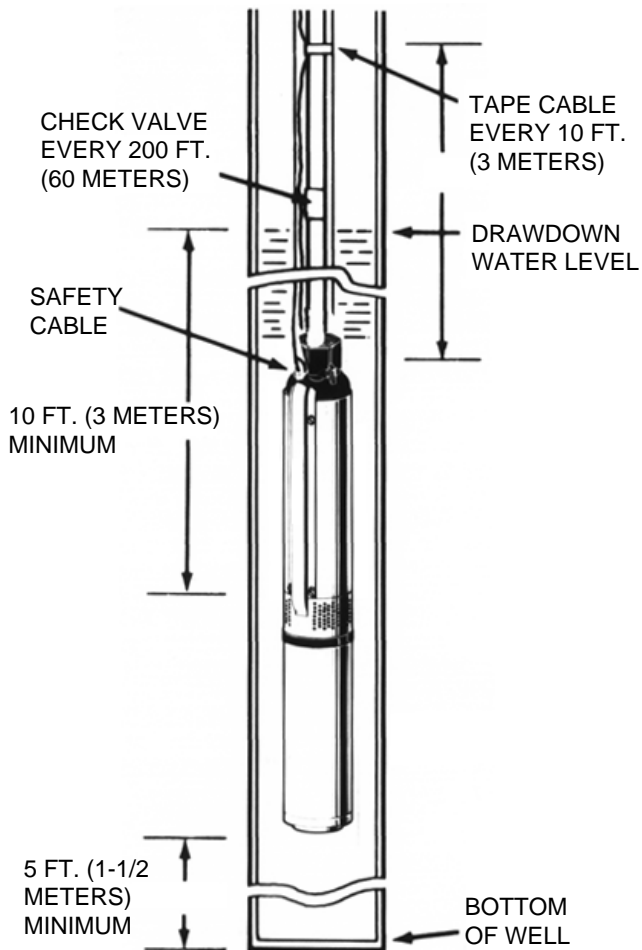

TO PRESSURE SWITCH (2-WIRE)  
TO CONTROL BOX (3-WIRE)

OPTIONAL GATE VALVE

## COMPLETE WELL SEAL INSTALLATION



## CABLE SPLICE CHECK

You must check pump cables and splices for electrical leaks with an ohmmeter. Refer to drawing to the right.  
**STEP 1:** Fill a bucket with water. Submerge pump cables and splices completely. Leave bare wire ends of cables out of the water.

**STEP 2:** With the ohmmeter selector knob on Rx 100K and the ohmmeter leads clipped together, adjust the ohmmeter needle to zero.

**STEP 3:** Submerge one ohmmeter lead in the water. Clip the other lead to first one bare wire end, then the other. If the ohmmeter reads infinity ( $\infty$ ), the cable splice is watertight. If the needle deflects to zero on either cable, there is a leak in the splice, or damage to the cable insulation. Slowly pull the cable that registered zero from the water. The point at which the needle falls back to infinity ( $\infty$ ) is the point on the cable where it is damaged, or has a leaky splice. It must be repaired with a cable splice kit.

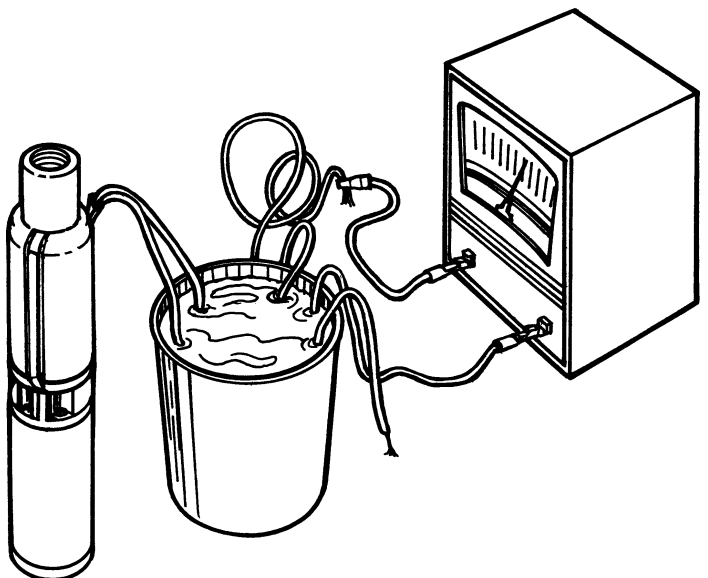

# ELECTRICAL CONNECTIONS

**WARNING:** Make sure power is off before doing any electrical work.

**2-WIRE** (no control box required): Remove pressure switch cover. Connect two pump wires to the two inside pressure switch terminals (numbers 2 & 3). Run wires from two outside pressure switch terminals (numbers 1 & 4) to fuse box/power supply. Connect green ground wire to the two ground screws on base of pressure switch.

**3-WIRE:** Connect red, black, and yellow pump wires to control box terminals labelled "R", "B", and "Y" respectively. Connect green ground wire to one of the screws labelled "GND". Remove pressure switch cover. Run a wire from other "GND" screw to one of the ground screws at base of pressure switch. Run wires from control box terminals labelled "L1" and "L2" to two inside pressure switch terminals (numbers 2 & 3). Run wires from two outside pressure switch terminals (lines 1 & 4) to fuse box/power supply. Run wire from ground screw to fuse box ground bar.

\* For Minimum Entrance Box Service Rating see chart below.

## 2-WIRE CONNECTIONS

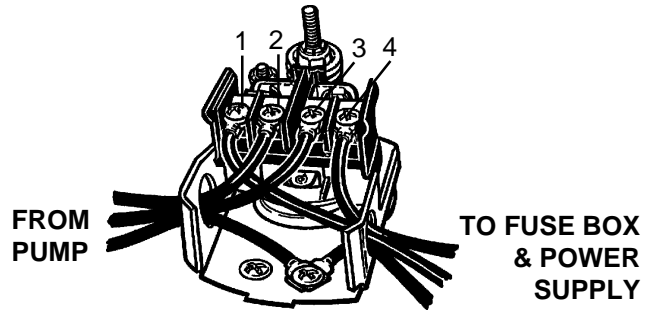

## 3-WIRE CONNECTIONS

### CONTROL BOXES NEEDED

- RF303 for 1/2 hp pumps
- RF304 for 3/4 hp pumps
- RF305 for 1 hp pumps
- RF306 for 1-1/2 hp pumps
- R3071B for 2 hp pumps

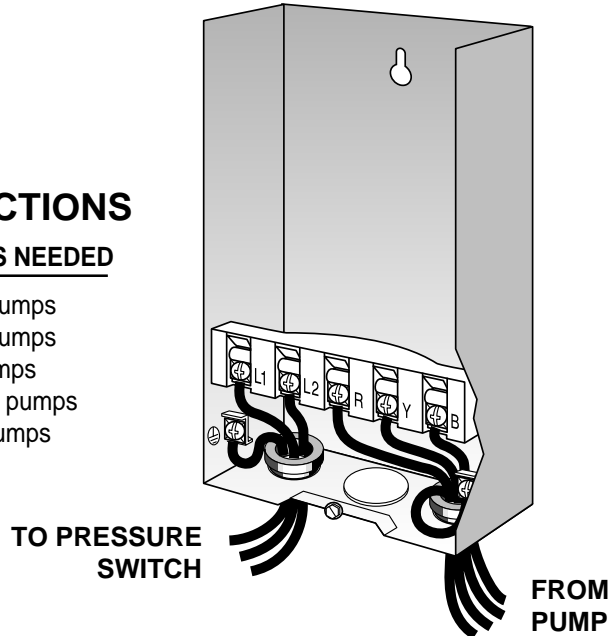
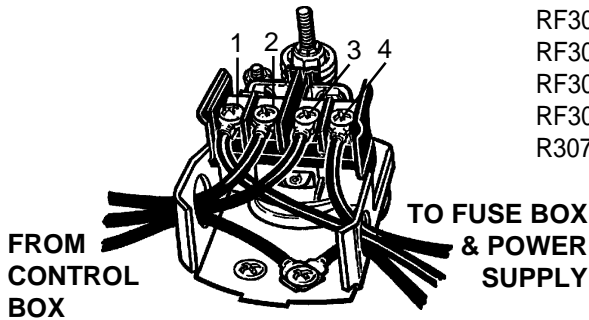

## FUSE AND CIRCUIT BREAKER SIZE GUIDE

PUMP WIRING	HORSE POWER	NAME PLATE VOLTS	APPROX. MAX. AMPS	LOCKED ROTOR AMPS	CIRCUIT & STD. FUSE	TIME RELAY & FUSETRON CARTRIDGE
TWO WIRE	1/2	115	11.9	62.4	30	15
	1/2	230	5.9	31.2	15	7
	3/4	230	8.0	40.2	20	9
	1	230	9.6	46.0	25	12
	1-1/2	230	13.1	56.8	35	15
THREE WIRE	1/2	230	5.9	23.1	15	7
	3/4	230	8.0	33.1	20	9
	1	230	9.6	42.0	25	12
	1-1/2	230	11.6	52.8	30	15

## FRANKLIN 4 INCH MOTOR MINIMUM SERVICE REQUIREMENTS

HP	Volts	Wire	Minimum Service
1/3	115	2W	200 amp
1/3	115	3W	200 amp
1/3	230	2W	60 amp
1/3	230	3W	60 amp
1/2	115	2W	200 amp
1/2	115	3W	200 amp
1/2	230	2W	60 amp
1/2	230	3W	60 amp
3/4	230	2W	100 amp
3/4	230	3W	100 amp
1	230	2W	100 amp
1	230	3W	100 amp
1-1/2	230	2W	200 amp
1-1/2	230	3W	200 amp

## SUBMERSIBLE PUMP CABLE SIZE GUIDE

HORSE POWER	NAME PLATE VOLTS	MAX. CABLE LENGTH IN FEET USING AWG CABLE SIZE		
		#14	#12	#10
1/2	115	100	160	250
1/2	230	400	650	1020
3/4	230	300	480	760
1	230	250	400	630
1-1/2	230	190	310	480

# PUMP SPECIFICATIONS

DISCH. PRESS.	PUMP MODEL	GPM	HP	PUMPING DEPTH IN FEET - CAPACITIES IN GALLONS PER MINUTE														
				20	40	60	80	100	125	150	175	200	250	300	350	400	450	500
40	R200A R201A R300A	10	1/2		14.5	13.0	11.5	9.8	7.0									
	R3065A	6	1/2		7.9	7.6	7.3	6.9	6.5	6.0	5.4	4.6						
	R202A R301A	10	3/4			15.5	14.0	13.0	12.2	9.4								
	R3067A	6	3/4				8.0	7.8	7.6	7.3	6.9	6.6	5.7	4.8	3.5			
	R3207A	18	3/4	21.5	19.5	16.0												
	R203A R302A	10	1					15.3	14.5	13.0	11.6	10.5						
	R30610A	6	1						8.0	7.8	7.6	7.4	6.8	6.3	5.7	4.9	3.9	2.5
	R3183A	18	1		23.0	21.5	20.0	17.5	14.0									
	R31015A	10	1-1/2									14.9	13.4	11.7	9.7	7.3		
	R214A R314A	6	1-1/2									11.5	10.8	10.0	9.0	7.7	6.4	4.6
	R3184A	18	1-1/2				23.5	22.5	21.5	19.3	16.5							
	R2254A R3254A	25	1-1/2						26.5	21.8	15.8							
	R2354A R3354A	35	1-1/2	42.9	35.2	27.5												
	R32551A	25	2						30.1	26.3	25.1	17.2						
R33551A	35	2			42.0	33.0	31.1											
50	R200A R201A R300A	10	1/2	14.5	13.0	11.5	9.8											
	R3065A	6	1/2	7.9	7.6	7.3	6.9	6.5	6.3	5.4	4.7	3.9						
	R202A R301A	10	3/4		15.5	14.5	13.4	12.2	10.8	8.5								
	R3067A	6	3/4			8.0	7.7	7.6	7.4	6.9	6.5	6.2	5.3	4.3				
	R3207A	18	3/4	19.5	16.0													
	R203A R302A	10	1				15.3	14.5	13.5	12.0	10.5	9.2						
	R30610A	6	1					8.0	7.8	7.7	7.5	7.2	6.6	6.0	5.3	4.6	3.5	
	R3183A	18	1	23.0	21.5	20.0	17.5											
	R31015A	10	1-1/2								14.9	14.3	12.8	11.0	8.8			
	R214A R314A	6	1-1/2								11.5	11.3	10.4	9.6	8.5	7.3	5.6	
	R3184A	18	1-1/2			23.5	22.5	21.5	20.0	17.5	14.5							
	R2254A R3254A	25	1-1/2			29.2	22.2	16.0										
	R2354A R3354A	35	1-1/2	35.3														
	R32551A	25	2						26.6	22.4	17.2							
R33551A	35	2	45.6	37.5	36.2	27.0												
60	R200A R201A R300A	10	1/2	12.6	11.2	9.2												
	R3065A	6	1/2	7.5	7.2	6.8	6.5	6.1	5.3	4.7	4.0							
	R202A R301A	10	3/4		14.2	13.0	11.8	10.5	8.5									
	R3067A	6	3/4			7.7	7.6	7.4	7.0	6.6	6.2	5.8	5.0					
	R3207A	18	3/4	15.3														
	R203A R302A	10	1				14.4	13.4	12.1	10.7	9.3	7.4						
	R30610A	6	1				8.0	7.9	7.7	7.5	7.2	6.9	6.5	5.7	5.0	4.2		
	R3183A	18	1	22.5	21.2	20.0												
	R31015A	10	1-1/2							14.9	14.3	13.6	12.0	10.0	7.6			
	R214A R314A	6	1-1/2								11.2	10.8	10.2	9.2	8.0	6.6	5.0	
	R3184A	18	1-1/2		23.2	22.5	21.4	20.0	17.9	14.5								
	R2254A R3254A	25	1-1/2			25.4	21.0	15.0										
	R2354A R3354A	35	1-1/2															
	R32551A	25	2					26.9	22.8	18.0								
R33551A	35	2	40.5	33.1	28.9													

# TROUBLESHOOTING CHECKLIST (CAUTION: SHUT OFF POWER TO PUMP)

PROBLEM	POSSIBLE CAUSES
<b>Pump runs, but does not deliver water.</b>	<ul style="list-style-type: none"> <li>• Check valve is stuck. Shake pipe or raise and lower the unit. If pump still does not operate properly, remove pump from well and clear obstruction from check valve.</li> <li>• Low voltage to pump. Have voltage checked by an electrician.</li> <li>• Clogged intake. Clean screen or slots in inlet bowl.</li> <li>• Impellers and diffuser worn or packed with sand or debris. Clean or replace.</li> <li>• Low well water level. Lower pump deeper into the well or install flow restrictor.</li> <li>• Well too deep for pump. See charts on page 8 for appropriate operating depths.</li> <li>• Leaks. Check all connections for airtightness.</li> </ul>
<b>Pump won't run.</b>	<ul style="list-style-type: none"> <li>• Check for blown fuse or tripped circuit breaker and for broken or open leads in piping.</li> <li>• Pressure switch malfunction. Replace.</li> <li>• Control panel malfunction (3-wire pumps only). Have an electrician check it.</li> </ul>
<b>Pump starts too frequently.</b>	<ul style="list-style-type: none"> <li>• Pressure switch out of adjustment. Follow instructions on inside of switch cover.</li> <li>• Check valve stuck open or seated improperly. Clean or replace.</li> <li>• Pressure tank is water-logged. Bladder tanks: release air from tank air charge valve. If water bubbles or spits from valve, the bladder has a hole in it. Galvanized tanks: check for a defective air-volume control.</li> <li>• Leak in system.</li> </ul>
<b>Pump does not shut off automatically.</b>	<ul style="list-style-type: none"> <li>• Pressure switch out of adjustment. Follow instructions on inside of switch cover.</li> <li>• Defective pressure switch. Replace.</li> <li>• Worn pump.</li> <li>• Low well water level. Lower pump deeper into the well or install flow restrictor.</li> <li>• Well too deep for pump. See charts on page 8 for appropriate operating depths.</li> </ul>
<b>Pump blows fuses, trips breakers, or overloads.</b>	<ul style="list-style-type: none"> <li>• Fuses or breakers are too small. See fuse chart on page 7.</li> <li>• Wire size is too small. See wire size chart on page 7.</li> <li>• Motor or cable is grounded. Have an electrician check with an ohmmeter.</li> <li>• Voltage too high or too low. Have it checked by an electrician.</li> <li>• Incorrect control box (3-wire pumps only). Compare nameplate rating on box to pump HP.</li> </ul>

## LIMITED WARRANTY

WATER ACE PUMP CO. will repair or replace for the original user any portion of a new WATER ACE product which proves defective due to materials or workmanship of WATER ACE PUMP CO. Contact the nearest authorized WATER ACE PUMP dealer for warranty service. WATER ACE PUMP CO. shall possess the sole right to determine whether to repair or replace defective equipment, parts or components. THIS WARRANTY DOES NOT COVER DAMAGE DUE TO LIGHTNING OR OTHER CONDITIONS BEYOND THE CONTROL OF WATER ACE PUMP CO.

**PUMPS:** Warranted 12 months from date of purchase or 18 months from date of manufacture. Receipt and product date code required for warranty claim.

**LABOR & COSTS:** WATER ACE PUMP CO. shall IN NO EVENT be liable for the cost of field labor or other charges incurred by any customer in removing and/or reaffixing any WATER ACE PUMP product, part or component.

**THIS WARRANTY WILL NOT APPLY:** (a) to defects or malfunctions resulting from failure to properly install, operate, or maintain the unit in accordance with printed instructions provided; (b) to failures resulting from abuse, accident, or negligence; (c) to normal maintenance services and the parts used in connection with such service; (d) to units which are not installed in accordance with applicable local codes, ordinances, and good trade practices; (e) if the unit is moved from its original installation location; (f) if unit is used for purposes other than for what it was designed and manufactured.

**PRODUCT IMPROVEMENTS:** WATER ACE PUMP CO. reserves the right to change or improve its products or any component without obligation to provide such a change or improvement for units previously sold and/or shipped.

**WARRANTY EXCLUSIONS:** WATER ACE PUMP CO. SPECIFICALLY DISCLAIMS THE IMPLIED WARRANTIES OF MERCHANTABILITY AND FITNESS FOR A PARTICULAR PURPOSE AFTER THE TERMINATION OF THE WARRANTY PERIOD SET FORTH HEREIN.

Some states do not permit some or all of the above warranty limitations and, therefore, such limitations may not apply to you. No warranties or representations at any time made by any representatives of WATER ACE PUMP CO. shall vary or expand the provision hereof.

**LIABILITY LIMITATION:** IN NO EVENT SHALL WATER ACE PUMP CO. BE LIABLE OR RESPONSIBLE FOR CONSEQUENTIAL, INCIDENTAL OR SPECIAL DAMAGES RESULTING FROM OR RELATED IN ANY MANNER TO ANY WATER ACE PUMP PRODUCT OR PARTS THEREOF. PERSONAL INJURY AND/OR PROPERTY DAMAGE MAY RESULT FROM IMPROPER INSTALLATION. WATER ACE PUMP CO. DISCLAIMS ALL LIABILITY, INCLUDING LIABILITY UNDER THIS WARRANTY, FOR IMPROPER INSTALLATION - WATER ACE PUMP CO. RECOMMENDS FOLLOWING THE INSTRUCTIONS IN THE INSTALLATION MANUAL. WHEN IN DOUBT, CONSULT A PROFESSIONAL.

Some states do not allow the exclusion or limitation of incidental or consequential damages, so the above limitation or exclusion may not apply to you.

This warranty gives you specific legal rights and you may also have other rights which vary from state to state.

In the absence of suitable proof of this purchase date, the effective date of this warranty will be based upon the date of manufacture.

**Direct all Notices, etc. to: Product Warranty and Return Dept., Water Ace Pump Co., 1101 Myers Parkway, Ashland, OH 44805-1969.**



Water Ace Pump Co. • 1101 Myers Parkway • Ashland, Ohio 44805-1969  
1-800-942-3343 (U.S.A. only)